

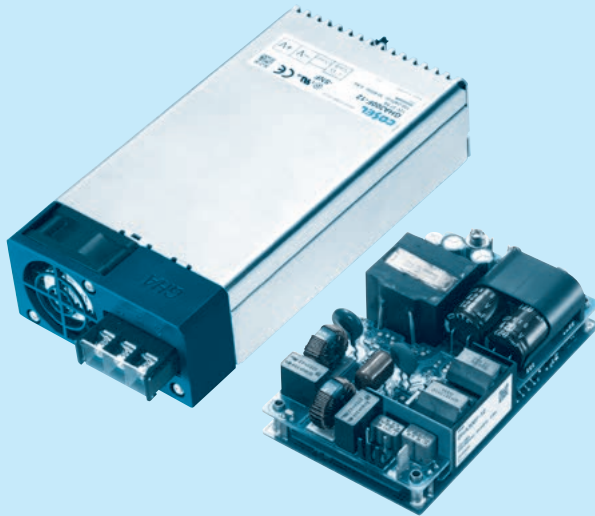

GHA-series

GHA series is an innovative model that offers a wide variety of cooling methods (convection, forced air, and conduction cooling).



GHA300F / GHA300F-SNF

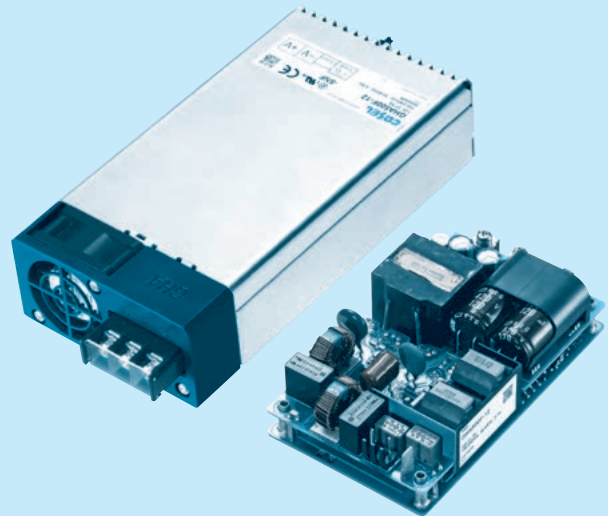

GHA500F / GHA500F-SNF

Feature

- Wattage 500Wmax
- Conduction cooling (GHA500F)
- 3" X 5" standard footprint
- Less than 1U high
- ITE and Medical safety approvals
- Low leakage current
- With Remote (Option)
- With AUX1(12V), AUX2(5V) (Option)
- With FAN (GHA300F-SNF, GHA500F-SNF)

Safety agency approvals

- UL60950-1, ANSI/AAMI ES60601-1
- C-UL (CSA60950-1, CAN/CSA60601-1)
- EN60950-1, EN60601-1 3rd
- Complies with DEN-AN

5-year warranty (Refer to Instruction Manual)

CE marking

- Low Voltage Directive
- RoHS Directive

EMI

- Complies with FCC-B, CISPR11-B, CISPR22-B, EN55011-B, EN55022-B, VCCI-B

EMS Compliance : EN61204-3, EN61000-6-2

IEC60601-1-2 (2014), EN60601-1-2 (2015)

- EN61000-4-2
- EN61000-4-3
- EN61000-4-4
- EN61000-4-5
- EN61000-4-6
- EN61000-4-8
- EN61000-4-11

GHA300F

GH A 300 F -□□ -□
 ① ② ③ ④ ⑤ ⑥

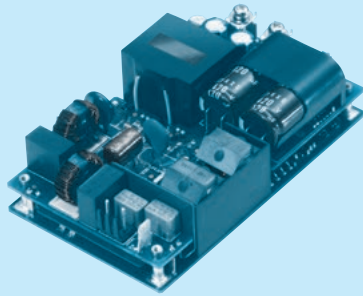

Example recommended EMI/EMC filter
EAC-10-472



High voltage pulse noise type : EAP series
 Low leakage current type : EAM series
 * A higher current rating EMI/EMC filter may be recommended in view of the other devices that could be connected in parallel with the power supply.

- ① Series name
 - ② Single output
 - ③ Output wattage
 - ④ Universal input
 - ⑤ Output voltage
 - ⑥ Optional *6
- T3 : mounting hole M3
 J1 : J.S.T.connector type
 J3 : Horizontal input connector
 J.S.T.connector type
 R3 : with Subfeatures (5VAUX,12VAUX,Remote, Power good)(Molex connector type)
 *with friction locks,J2R3

This power supply is manufactured by SMD technology. The stress to P.C.B like twisting or bending causes the defect of the unit, please handle the unit with care
 *Make sure necessary tests will be carried out on your end equipment with the power supply installed in accordance with any required EMC/EMI regulations.

Specification is changed at option, refer to Instruction manual.

MODEL	GHA300F-12		GHA300F-24		GHA300F-48	
MAX OUTPUT WATTAGE[W]	300		300		302.4	
DC OUTPUT	Forced air	at 50°C	12V 25A	24V 12.5A	48V 6.3A	
		at 40°C	12V 8.4A	24V 4.2A	48V 2.1A	
	Convection	at 50°C	12V 4.5A	24V 2.2A	48V 1.1A	

SPECIFICATIONS

	MODEL	GHA300F-12		GHA300F-24		GHA300F-48		
INPUT	VOLTAGE[V]	AC90 - 264 1 φ (output derating is required at AC90V -115V *3)						
	CURRENT[A]	ACIN 120V	3.3typ		90typ		90typ	
		ACIN 230V	1.8typ		92typ		92typ	
	FREQUENCY[Hz]	50 / 60 (47 - 63)						
	EFFICIENCY[%]	ACIN 120V	89typ		90typ		90typ	
		ACIN 230V	91typ		92typ		92typ	
	POWER FACTOR (Io=100%)	ACIN 120V	0.95typ		90typ		90typ	
		ACIN 230V	0.90typ		92typ		92typ	
INRUSH CURRENT[A]	ACIN 120V	20typ (Io=100%) (At cold start) (Ta=25°C)						
	ACIN 230V	40typ (Io=100%) (At cold start) (Ta=25°C)						
LEAKAGE CURRENT[mA]	0.125/0.250max (ACIN 120V/240V 60Hz,Io=100%, According to IEC60601-1)							
OUTPUT	VOLTAGE[V]	12		24		48		
	CURRENT[A]	Forced air	25.0		12.5		6.3	
		Convection	4.5		2.2		1.1	
	LINE REGULATION[mV]	*4 48max		96max		192max		
	LOAD REGULATION[mV]	*4 100max		150max		240max		
	RIPPLE[mVp-p]	*1 0 to +50°C	240max		240max		300max	
		-20 to 0°C	320max		320max		400max	
	RIPPLE NOISE[mVp-p]*1	0 to +50°C	300max		300max		480max	
		-20 to 0°C	360max		360max		500max	
	TEMPERATURE REGULATION[mV]	0 to +50°C	120max		240max		480max	
		-20 to +50°C	150max		290max		600max	
	DRIFT[mV]	*2 48max		96max		192max		
	START-UP TIME[ms]	500typ (ACIN 120V, Io=100%)						
	HOLD-UP TIME[ms]	16typ (ACIN 120V, Io=100%)						
OUTPUT VOLTAGE ADJUSTMENT RANGE[V]	10.80 to 13.20		21.60 to 26.40		43.20 to 52.80			
OUTPUT VOLTAGE SETTING[V]	12.00 to 12.48		24.00 to 24.96		48.00 to 49.92			
PROTECTION CIRCUIT AND OTHERS	OVERCURRENT PROTECTION	Works over 105% of rating and recovers automatically						
	OVERVOLTAGE PROTECTION[V]	13.80 to 16.80		27.60 to 33.60		55.20 to 67.20		
	AUX1 (12V1A)	Optional						
	AUX2 (5V1A)	Optional						
	REMOTE ON/OFF	Optional						
ISOLATION	PowerGood	Optional						
	INPUT-OUTPUT · RC · AUX *7	AC4,000V 1minute, Cutoff current = 10mA, DC500V 50MΩ min (At Room Temperature) 2MOPP						
	INPUT-FG	AC2,000V 1minute, Cutoff current = 10mA, DC500V 50MΩ min (At Room Temperature) 1MOPP						
	OUTPUT · RC · AUX-FG *7	AC500V 1minute, Cutoff current = 25mA, DC500V 50MΩ min (At Room Temperature)						
ENVIRONMENT	OUTPUT-RC · AUX *7	AC500V 1minute, Cutoff current = 25mA, DC500V 50MΩ min (At Room Temperature)						
	OPERATING TEMP.,HUMID.AND ALTITUDE	-20 to +70°C, 20 - 90%RH (Non condensing), 3,000m (10,000feet) max *3						
	STORAGE TEMP.,HUMID.AND ALTITUDE	-30 to +75°C, 20 - 90%RH (Non condensing), 9,000m (30,000feet) max						
	VIBRATION	10 - 55Hz, 19.6m/s ² (2G), 3minutes period, 60minutes each along X, Y and Z axis						
SAFETY AND NOISE REGULATIONS	IMPACT	196.1m/s ² (20G), 11ms, once each X, Y and Z axis						
	AGENCY APPROVALS	UL60950-1, ANSI/AAMI ES60601-1, C-UL(CSA60950-1, CAN/CSA60601-1), EN60950-1, EN60601-1 3rd, Complies with DEN-AN, IEC60601-1-2 4th Ed.						
	CONDUCTED NOISE	Complies with FCC-B, VCCI-B, CISPR11-B, CISPR22-B, EN55011-B, EN55022-B						
	HARMONIC ATTENUATOR	Complies with IEC61000-3-2 (class A) *5						
OTHERS	CASE SIZE/WEIGHT	76.2 X 35 X 127mm [3.0 X 1.4 X 5.0 inches] (W X H X D) / 400g max						
	COOLING METHOD	Convection, Forced air (Require external fan)						

*1 This is the value that measured on measuring board with capacitor of 22 μF at 150mm from output terminal.
 Measured by 20MHz oscilloscope or Ripple-Noise meter (Equivalent to KEISOKU-GIKEN: RM103).
 *2 Drift is the change in DC output for an eight hour period after a half-hour warm-up at 25°C, with the input voltage held constant at the rated input/output.
 *3 Derating is required.
 *4 Please contact us about dynamic load and input response.
 *5 Please contact us about another class.

*6 Specification is changed at option, refer to Instruction Manual
 *7 Applicable when AUX and remote control (optional) is added.
 * To meet the specifications. Do not operate over-loaded condition.
 * Sound noise may be generated by power supply in case of pulse load.
 * Parallel operation is not possible.
 * Forced air cooling is required to output up to MAX OUTPUT WATTAGE.
 * Bottom layer P.C.B has electric potential which is required isolation from FG by clearance or creepage as the safety design issue.

Features

- High Power density: 14.3W/inch³
- 3" × 5" standard footprint
- Industrial and Medical safety approvals
- With Remote On/Off (Optional)
- No minimum load is required
- High efficiency 92% typ (Input Voltage 230V, Output Voltage 24V)
- Fits 1U applications
- Low leakage current
- With AUX1 (12V), AUX2 (5V) (Optional)

Block diagram

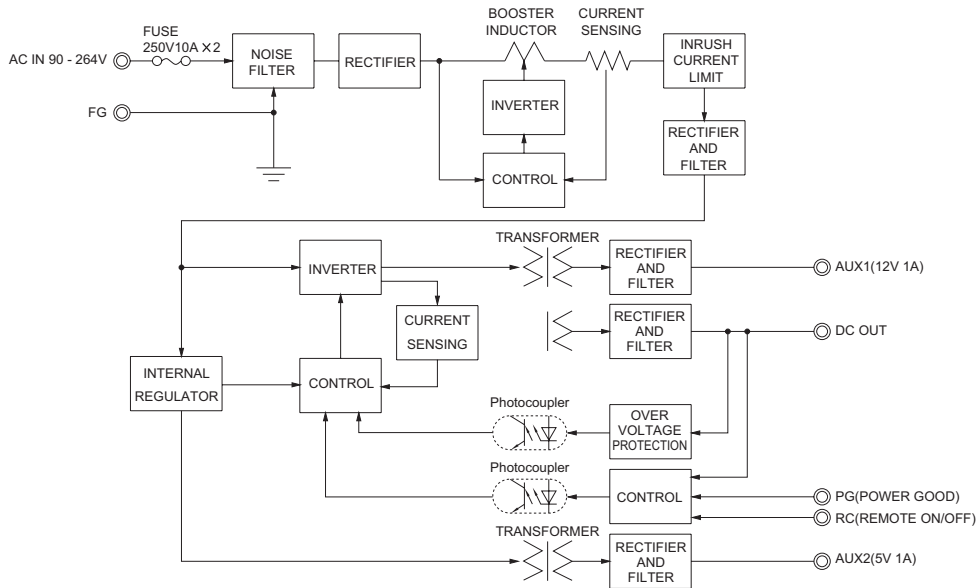

External view

*External size of option J3 is different from standard model and refer to 6 Option and Others of instruction manual for details.

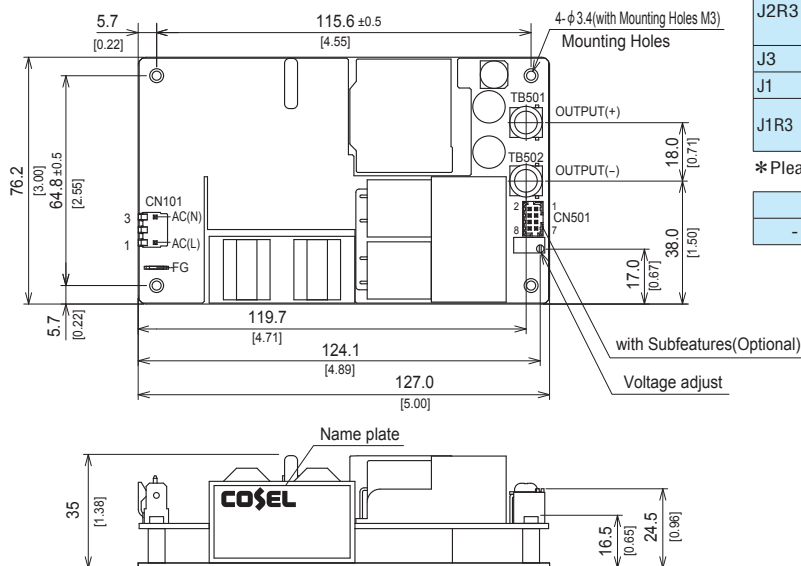

- ※ Tolerance ± 1 [± 0.04]
- ※ Weight : 400g max
- ※ There is a total of four attachment holes.
- ※ This power supply requires mounting on metal standoffs 5mm in height. (Insulating sheet is required if you do not use a spacer).
- ※ Dimensions in mm, []=inches
- ※ Screw tightening torque : (TB501, 502) : 1.5N · m max
- ※ Mounting torque : 0.6N · m max
- ※ Avoid contact between TB501 and 502 wiring with mounting parts.
- ※ Option : -J1 : (J.S.T) connector type. Refer to Instruction Manual 6.

		Connector	Mating connector	Terminal	Mfr
Standard	CN101	A-41671-A03A197-2	09-50-8031	08-50-0105 08-65-0114	Molex *
	CN501	087831-0820	51110-0851	50394-8051	
	CN501	087831-0841	51110-0860	50394-8051	
J2R3	CN101	A-41671-A03A197-2	09-50-8031	08-50-0105 08-65-0114	J.S.T.
J3	CN101	S2P3-VH			
J1	CN101	B2P3-VH	VHR-3N	SVH-21T-P1.1	J.S.T.
J1R3	CN501	B8B-PHDSS	PHDR-08VS	SPHD-002T-P0.5	

*Please note the pin position No.1 is different from Molex.

FG	Mating connector	Terminal	Mfr
-	250 Series	-	Tyco Electronics

<Pin Assignments>

<CN101>

Pin No.	Input
1	AC(L)
2	
3	AC(N)

<CN501(Optional)>

Pin No.	Function
1	AUX1 : AUX1 (12V1A)
2	AUX1G: AUX1 (GND)
3	RC : REMOTE ON/OFF
4	RCG : REMOTE ON/OFF (GND)
5	PG : Power good
6	PGG : Power good (GND)
7	AUX2 : AUX2 (5V1A)
8	AUX2G: AUX2 (GND)



CN501

GHA500F

GH A 500 F -□□ -□
 ① ② ③ ④ ⑤ ⑥

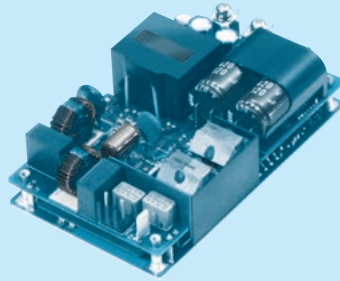

Example recommended EMI/EMC filter EAC-10-472



High voltage pulse noise type : EAP series
 Low leakage current type : EAM series
 * A higher current rating EMI/EMC filter may be recommended in view of the other devices that could be connected in parallel with the power supply.

- ① Series name
 - ② Single output
 - ③ Output wattage
 - ④ Universal input
 - ⑤ Output voltage
 - ⑥ Optional *6
- T3 : mounting hole M3
 J1 : J.S.T.connector type
 J3 : Horizontal input connector J.S.T.connector type
 R3 : with Subfeatures (5VAUX,12VAUX,Remote, Power good)(Molex connector type)
 *with friction locks,J2R3
 P : Parallel Operation

This power supply is manufactured by SMD technology. The stress to P.C.B like twisting or bending causes the defect of the unit, please handle the unit with care
 *Make sure necessary tests will be carried out on your end equipment with the power supply installed in accordance with any required EMC/EMI regulations.

Specification is changed at option, refer to Instruction manual.

MODEL	GHA500F-12	GHA500F-15	GHA500F-24	GHA500F-30	GHA500F-48	GHA500F-56		
MAX OUTPUT WATTAGE[W]	500.4	501	504	501	504	504		
DC OUTPUT	Forced air Convection conduction cooling	at 50°C	12V 41.7A	15V 33.4A	24V 21.0A	30V 16.7A	48V 10.5A	
		at 40°C	12V 12.5A	15V 10.0A	24V 6.3A	30V 5.0A	48V 3.2A	56V 2.7A
		at 50°C	12V 9.2A	15V 7.4A	24V 4.6A	30V 3.7A	48V 2.3A	56V 1.9A
		at 0°C	12V 30.0A	15V 24.0A	24V 15.0A	30V 12.0A	48V 7.5A	56V 6.4A
	at 50°C	12V 16.7A	15V 13.4A	24V 8.4A	30V 6.7A	48V 4.2A	56V 3.6A	

SPECIFICATIONS

MODEL	GHA500F-12	GHA500F-15	GHA500F-24	GHA500F-30	GHA500F-48	GHA500F-56			
INPUT	VOLTAGE[V]	AC90 - 264 1 φ (output derating is required at AC90V -115V *3)							
	CURRENT[A]	ACIN 120V	5.4typ						
		ACIN 230V	2.9typ						
	FREQUENCY[Hz]	50 / 60 (47 - 63)							
	EFFICIENCY[%]	ACIN 120V	88typ	90typ	90typ	90typ	90typ		
		ACIN 230V	90typ	92typ	92typ	92typ	92typ		
	POWER FACTOR (lo=100%)	ACIN 120V	0.95typ						
		ACIN 230V	0.90typ						
	INRUSH CURRENT[A]	ACIN 120V	20typ (lo=100%) (At cold start) (Ta=25°C)						
		ACIN 230V	40typ (lo=100%) (At cold start) (Ta=25°C)						
LEAKAGE CURRENT[ma]	0.125/0.250max (ACIN 120V/240V 60Hz,lo=100%, According to IEC60601-1)								
OUTPUT	VOLTAGE[V]	12	15	24	30	48	56		
	CURRENT[A]	Forced air	41.7	33.4	21.0	16.7	10.5	9.0	
		Convection	9.2	7.4	4.6	3.7	2.3	1.9	
		conduction cooling	16.7	13.4	8.4	6.7	4.2	3.6	
	LINE REGULATION[mV]	*4	48max	60max	96max	120max	192max	192max	
	LOAD REGULATION[mV]	*4	100max	120max	150max	180max	240max	240max	
	RIPPLE[mVp-p]	*1	0 to +50°C	240max	240max	240max	300max	300max	400max
		-20 - 0°C	320max	320max	320max	400max	400max	500max	
	RIPPLE NOISE[mVp-p]*1	0 to +50°C	300max	300max	300max	480max	480max	500max	
		-20 - 0°C	360max	360max	360max	500max	500max	580max	
TEMPERATURE REGULATION[mV]	0 to +50°C	120max	150max	240max	300max	480max	480max		
	-20 to +50°C	150max	180max	290max	360max	600max	600max		
DRIFT[mV]	*2	48max	60max	96max	120max	192max	192max		
START-UP TIME[ms]	500typ (ACIN 120V, lo=100%)								
HOLD-UP TIME[ms]	16typ (ACIN 120V, lo=100%)								
OUTPUT VOLTAGE ADJUSTMENT RANGE[V]	10.80 to 13.20 13.50 to 16.50 21.60 to 26.40 27.00 to 31.50 43.20 to 52.80 52.00 to 56.00								
OUTPUT VOLTAGE SETTING[V]	12.00 to 12.48 15.00 to 15.30 24.00 to 24.96 30.00 to 31.20 48.00 to 49.92 55.00 to 56.00								
PROTECTION CIRCUIT AND OTHERS	OVERCURRENT PROTECTION	Works over 105% of rating and recovers automatically							
	OVERVOLTAGE PROTECTION[V]	13.80 to 16.80 17.25 to 21.00 27.60 to 33.60 34.50 to 42.00 55.20 to 67.20 60.00 to 69.00							
	AUX1 (12V1A)	Optional							
	AUX2 (5V1A)	Optional							
	REMOTE ON/OFF	Optional							
PowerGood	Optional								
ISOLATION	INPUT-OUTPUT · RC · AUX	*7 AC4,000V 1minute, Cutoff current = 10mA, DC500V 50MΩ min (At Room Temperature) 2MOPP							
	INPUT-FG	AC2,000V 1minute, Cutoff current = 10mA, DC500V 50MΩ min (At Room Temperature) 1MOPP							
	OUTPUT · RC · AUX-FG	*7 AC500V 1minute, Cutoff current = 25mA, DC500V 50MΩ min (At Room Temperature)							
	OUTPUT-RC · AUX	*7 AC500V 1minute, Cutoff current = 25mA, DC500V 50MΩ min (At Room Temperature)							
ENVIRONMENT	OPERATING TEMP., HUMID. AND ALTITUDE	-20 to +80°C, 20 - 90%RH (Non condensing), 3,000m (10,000feet) max							
	STORAGE TEMP., HUMID. AND ALTITUDE	-30 to +80°C, 20 - 90%RH (Non condensing), 9,000m (30,000feet) max							
	VIBRATION	10 - 55Hz, 19.6m/s ² (2G), 3minutes period, 60minutes each along X, Y and Z axis							
	IMPACT	196.1m/s ² (20G), 11ms, once each X, Y and Z axis							
SAFETY AND NOISE REGULATIONS	AGENCY APPROVALS	UL60950-1, ANSI/AAMI ES60601-1, C-UL(CSA60950-1, CAN/CSA60601-1), EN60950-1, EN60601-1 3rd, Complies with DEN-AN, IEC60601-1-2 4th Ed.							
	CONDUCTED NOISE	Complies with FCC-B, VCCI-B, CISPR11-B, CISPR22-B, EN55011-B, EN55022-B							
	HARMONIC ATTENUATOR	Complies with IEC61000-3-2 (class A) *5							
OTHERS	CASE SIZE/WEIGHT	76.2 X 35 X 127mm [3.0 X 1.4 X 5.0 inches] (W X H X D) / 420g max							
	COOLING METHOD	Convection, Forced air (Require external fan), Conduction cooling							

*1 This is the value that measured on measuring board with capacitor of 22 μF at 150mm from output terminal.
 Measured by 20MHz oscilloscope or Ripple-Noise meter (Equivalent to KEISOKU-GIKEN: RM103).
 *2 Drift is the change in DC output for an eight hour period after a half-hour warm-up at 25°C, with the input voltage held constant at the rated input/output.
 *3 Derating is required.
 *4 Please contact us about dynamic load and input response.

*5 Please contact us about another class.
 *6 Specification is changed at option, refer to Instruction Manual.
 *7 Applicable when AUX and remote control (optional) is added.
 * To meet the specifications. Do not operate over-loaded condition.
 * Sound noise may be generated by power supply in case of pulse load.
 * Parallel operation is available with -P option. Refer to 5.1 on the instruction manual.
 * Forced air cooling is required to output up to MAX OUTPUT WATTAGE.

Features

- **Wattage 500W max**
- **High efficiency 92% typ (Input Voltage 230V, Output Voltage 24V)**
- **Conduction cooling**
- **Fits 1U applications**
- **Low leakage current**
- **With AUX1 (12V), AUX2 (5V) (Optional)**
- **High Power density: 24.1W/inch³**
- **3" × 5" standard footprint**
- **Industrial and Medical safety approvals**
- **With Remote On/Off (Optional)**
- **No minimum load is required**

Block diagram

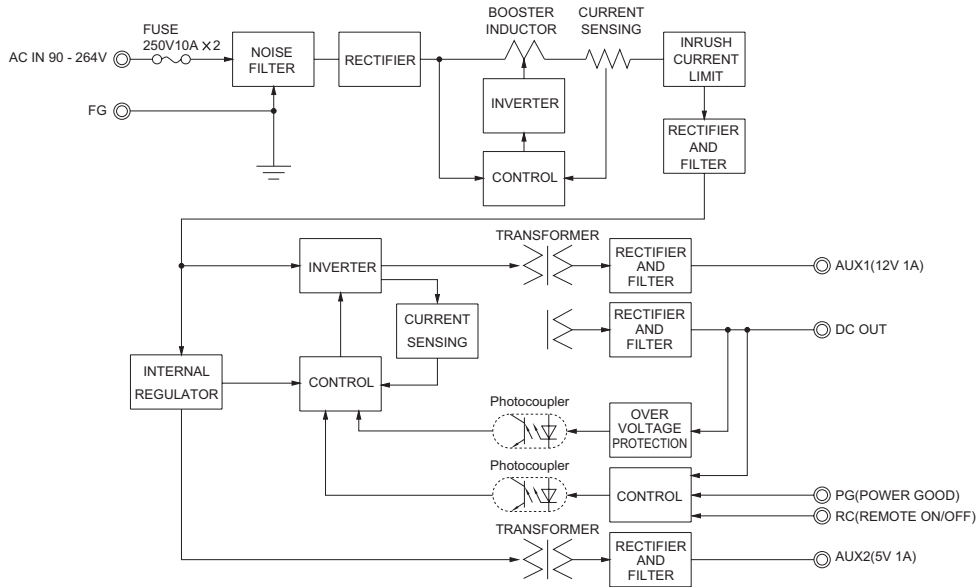

External view

* External size of option J3 is different from standard model and refer to 6 Option and Others of instruction manual for details.

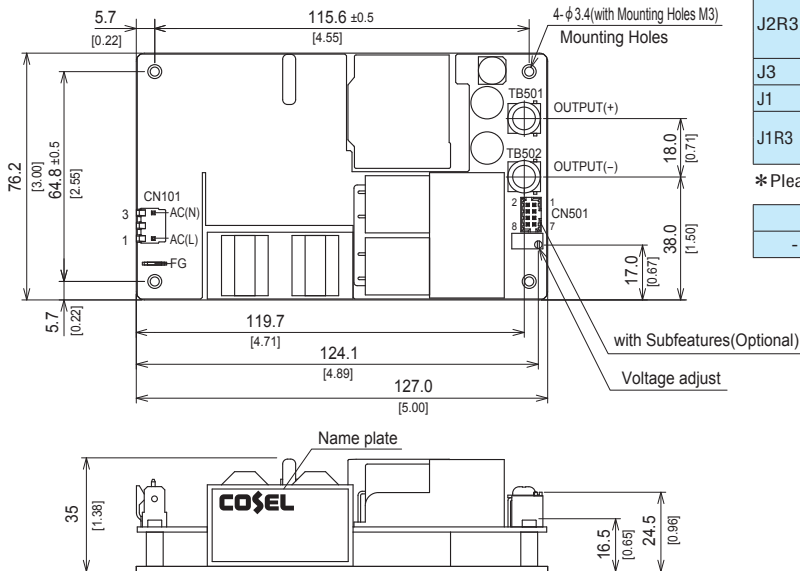

- ※ Tolerance ± 1 [± 0.04]
- ※ Weight : 420g max
- ※ There is a total of four attachment holes.
- ※ Base Plate : Aluminum
- ※ Dimensions in mm, []=inches
- ※ Screw tightening torque : (TB501, 502) : 1.5N · m max
- ※ Mounting torque : 0.6N · m max
- ※ Avoid contact between TB501 and 502 wiring with mounting parts.
- ※ Option : J1 : (J.S.T) connector type. Refer to Instruction Manual 6.

Connector		Mating connector	Terminal	Mfr	
Standard	CN101	A-41671-A03A197-2	09-50-8031	08-50-0105	Molex *
	CN101			08-65-0114	
R3	CN501	087831-0820	51110-0851	50394-8051	
	CN501				
J2R3	CN101	A-41671-A03A197-2	09-50-8031	08-50-0105	J.S.T.
	CN501	087831-0841	51110-0860	50394-8051	
J3	CN101	S2P3-VH			J.S.T.
J1	CN101	B2P3-VH	VHR-3N	SVH-21T-P1.1	
J1R3	CN501	B8B-PHDSS	PHDR-08VS	SPHD-002T-P0.5	

* Please note the pin position No.1 is different from Molex.

FG	Mating connector	Terminal	Mfr
-	250 Series	-	170603-2 Tyco Electronics

<Pin Assignments>

<CN101>

Pin No.	Input
1	AC(L)
2	
3	AC(N)

<CN501 (Optional)>

Pin No.	Function
1	AUX1 : AUX1 (12V1A)
2	AUX1G: AUX1 (GND)
3	RC : REMOTE ON/OFF
4	RCG : REMOTE ON/OFF (GND)
5	PG : Power good
6	PGG : Power good (GND)
7	AUX2 : AUX2 (5V1A)
8	AUX2G: AUX2 (GND)

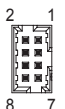

CN501

GHA300F-SNF

GH A 300 F -□□ -SNF□
 ① ② ③ ④ ⑤ ⑥

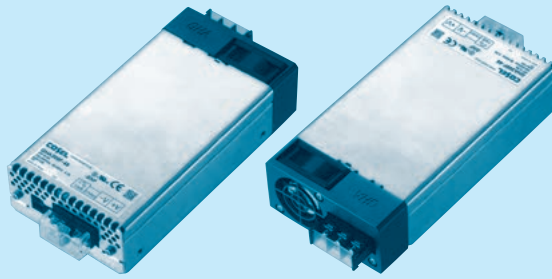

Example recommended EMI/EMC filter
EAC-10-472



High voltage pulse noise type : EAP series
 Low leakage current type : EAM series
 *A higher current rating EMI/EMC filter may be recommended in view of the other devices that could be connected in parallel with the power supply.

- ① Series name
 - ② Single output
 - ③ Output wattage
 - ④ Universal input
 - ⑤ Output voltage
 - ⑥ Optional *6
 - J1 : CN501
PHconnector type(J.S.T.)
 - J2 : CN501
Friction locks connector type (Molex)
- Refer to the instruction manual 6.1.

*Make sure necessary tests will be carried out on your end equipment with the power supply installed in accordance with any required EMC/EMI regulations.

MODEL	GHA300F-12-SNF	GHA300F-24-SNF	GHA300F-48-SNF
MAX OUTPUT WATTAGE[W]	300	300	302.4
DC OUTPUT	Forced air +50°C 12V 25.0A	24V 12.5A	48V 6.3A

SPECIFICATIONS

	MODEL	GHA300F-12-SNF	GHA300F-24-SNF	GHA300F-48-SNF	
INPUT	VOLTAGE[V]	AC90 - 264 1 φ (output derating is required at AC90V -115V *3)			
	CURRENT[A]	ACIN 120V	3.3typ		
		ACIN 230V	1.8typ		
	FREQUENCY[Hz]	50 / 60 (47 - 63)			
	EFFICIENCY[%]	ACIN 120V	88typ	89typ	89typ
		ACIN 230V	90typ	91typ	91typ
	POWER FACTOR (Io=100%)	ACIN 120V	0.95typ		
		ACIN 230V	0.90typ		
INRUSH CURRENT[A]	ACIN 120V	20typ (Io=100%) (At cold start) (Ta=25°C)			
	ACIN 230V	40typ (Io=100%) (At cold start) (Ta=25°C)			
LEAKAGE CURRENT[ma]	0.125/0.250max (ACIN 120V/240V 60Hz,Io=100%, According to IEC60601-1)				
OUTPUT	VOLTAGE[V]	12	24	48	
	CURRENT[A]	Forced air 25.0	12.5	6.3	
	LINE REGULATION[mV]	*4 48max	96max	192max	
	LOAD REGULATION[mV]	*4 100max	150max	240max	
	RIPPLE[mVp-p] *1	0 to +50°C	240max	240max	300max
		-20 - 0°C	320max	320max	400max
	RIPPLE NOISE[mVp-p]*1	0 to +50°C	300max	300max	480max
		-20 - 0°C	360max	360max	500max
	TEMPERATURE REGULATION[mV]	0 to +50°C	120max	240max	480max
		-20 to +50°C	150max	290max	600max
	DRIFT[mV]	*2 48max	96max	192max	
	START-UP TIME[ms]	500typ (ACIN 120V, Io=100%)			
	HOLD-UP TIME[ms]	16typ (ACIN 120V, Io=100%)			
	OUTPUT VOLTAGE ADJUSTMENT RANGE[V]	10.80 to 13.20	21.60 to 26.40	43.20 to 52.80	
OUTPUT VOLTAGE SETTING[V]	12.00 to 12.48	24.00 to 24.96	48.00 to 49.92		
PROTECTION CIRCUIT AND OTHERS	OVERCURRENT PROTECTION	Works over 105% of rating and recovers automatically *7			
	OVERVOLTAGE PROTECTION[V]	13.80 to 16.80	27.60 to 33.60	55.20 to 67.20	
	AUX1	10V 0.5A			
	AUX2	5V 1A			
	REMOTE ON/OFF	Possible, AUX2 is available			
PowerGood	Open collector				
ISOLATION	INPUT-OUTPUT · RC · AUX	AC4,000V 1minute, Cutoff current = 10mA, DC500V 50MΩ min (At Room Temperature) 2MOPP			
	INPUT-FG	AC2,000V 1minute, Cutoff current = 10mA, DC500V 50MΩ min (At Room Temperature) 1MOPP			
	OUTPUT · RC · AUX-FG	AC500V 1minute, Cutoff current = 25mA, DC500V 50MΩ min (At Room Temperature)			
	OUTPUT-RC · AUX	AC500V 1minute, Cutoff current = 25mA, DC500V 50MΩ min (At Room Temperature)			
ENVIRONMENT	OPERATING TEMP.,HUMID.AND ALTITUDE	-20 to +70°C, 20 - 90%RH (Non condensing), 3,000m (10,000feet) max *3			
	STORAGE TEMP.,HUMID.AND ALTITUDE	-30 to +75°C, 20 - 90%RH (Non condensing), 9,000m (30,000feet) max			
	VIBRATION	10 - 55Hz, 19.6m/s ² (2G), 3minutes period, 60minutes each along X, Y and Z axis			
	IMPACT	196.1m/s ² (20G), 11ms, once each X, Y and Z axis			
SAFETY AND NOISE REGULATIONS	AGENCY APPROVALS	UL60950-1, ANSI/AAMI ES60601-1, C-UL(CSA60950-1, CAN/CSA60601-1), EN60950-1, EN60601-1 3rd, Complies with DEN-AN, IEC60601-1-2 4th Ed.			
	CONDUCTED NOISE	Complies with FCC-B, VCCI-B, CISPR11-B, CISPR22-B, EN55011-B, EN55022-B			
	HARMONIC ATTENUATOR	Complies with IEC61000-3-2 (class A) *5			
OTHERS	CASE SIZE/WEIGHT	85.2 X 41 X 165.3mm [3.35 X 1.61 X 6.5 inches] (W X H X D) / 620g max			
	COOLING METHOD	Forced air			

*1 This is the value that measured on measuring board with capacitor of 22 μF at 150mm from output terminal.

Measured by 20MHz oscilloscope or Ripple-Noise meter (Equivalent to KEISOKU-GIKEN: RM103).

*2 Drift is the change in DC output for an eight hour period after a half-hour warm-up at 25°C, with the input voltage held constant at the rated input/output.

*3 Refer to "Derating".

*4 Please contact us about dynamic load and input response.

*5 Please contact us about another class.

*6 Specification is changed at option, refer to Instruction Manual.

*7 When output current more than rated, output will shut down after 5 seconds or more. Recycle input after 3 minutes to reset the protection.

* To meet the specifications. Do not operate over-loaded condition.

* Sound noise may be generated by power supply in case of pulse load.

Features

- Full packaged design united with GHA's features and additional robustness..
- High efficiency 91% typ (Input voltage 230V, Output voltage 24V)
- Optical for 1U applications
- Medical and Industrial safety approvals
- Low leakage current
- Conformal coating
- Single remote ON/OFF control for DC output, AUX1 and Fan.
- Isolated dual AUX (AUX1 10V 0.5A, AUX2 5V 1A)

Block diagram

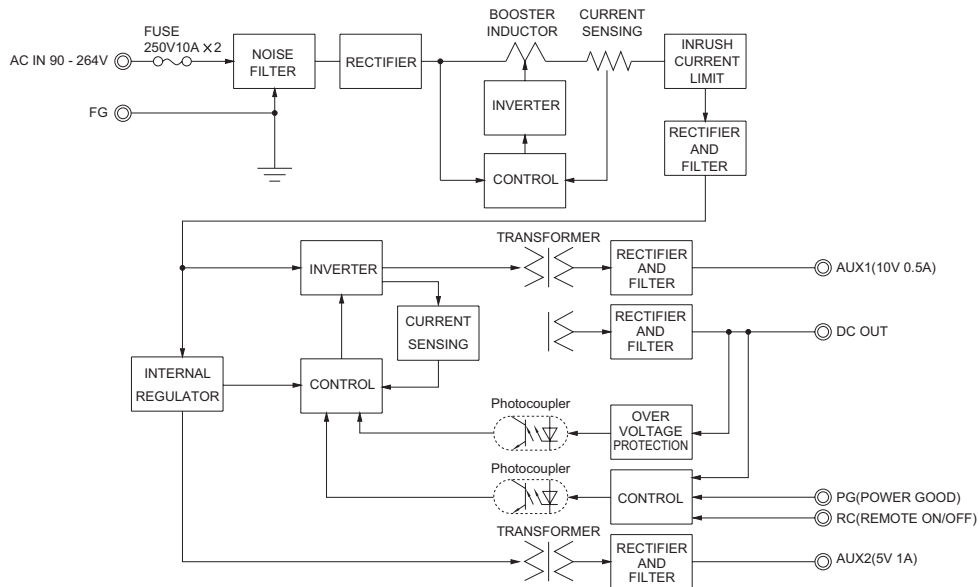

External view

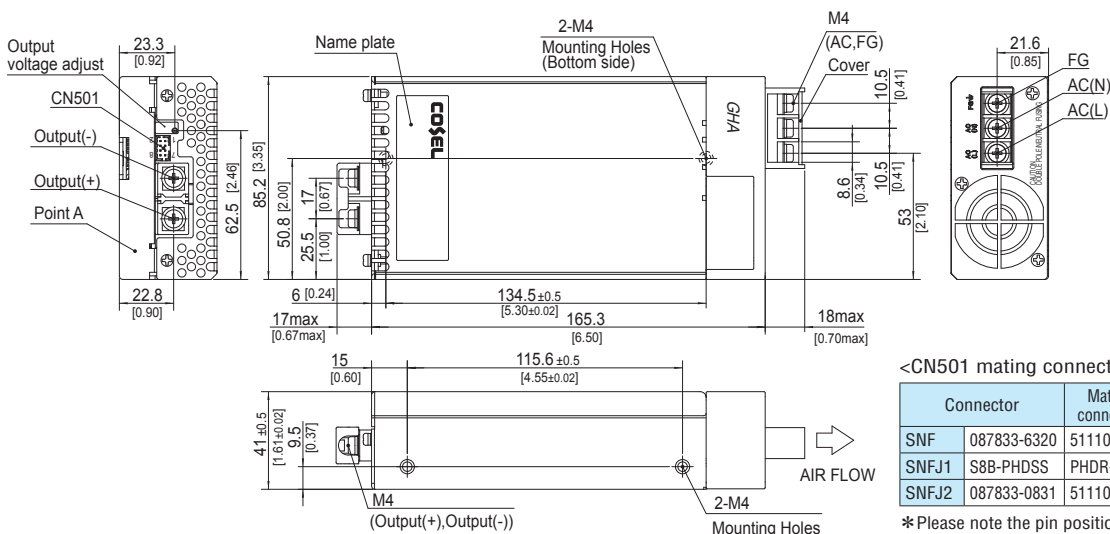

- ※ Tolerance $\pm 1 [\pm 0.04]$
- ※ Weight : 620g max
- ※ Upper PCB Material/thickness : FR-4/1.6mm
- ※ Lower PCB Material/thickness : FR-4/1.6mm
- ※ Chassis Material/thickness : Aluminum/1.5mm
- ※ Cover Material/thickness : Aluminum/1.2mm
- ※ Fan cover Material : PBT
- ※ Mounting torque : 1.5N · m (14.7kgf · cm) max
- ※ Screw tightening torque M4 : 1.6N · m (16.9kgf · cm) max
- ※ Dimensions in mm, []=inches



<CN501 mating connector and terminal>

Connector	Mating connector	Terminal	Mfr	
SNF	087833-6320	51110-0851	50394-8051	Molex *
SNFJ1	S8B-PHDSS	PHDR-08VS	SPHD-002T-P0.5	J.S.T.
SNFJ2	087833-0831	51110-0860	50394-8051	Molex *

* Please note the pin position No.1 is different from Molex.

<CN501>

Pin No.	Function
1	AUX1 : AUX1 (10V0.5A)
2	AUX1G: AUX1 (GND)
3	RC : REMOTE ON/OFF
4	RCG : REMOTE ON/OFF (GND)
5	PG : Power good
6	PGG : Power good (GND)
7	AUX2 : AUX2 (5V1A)
8	AUX2G: AUX2 (GND)

GHA500F-SNF

GH A 500 F -□□ -SNF□
 ① ② ③ ④ ⑤ ⑥

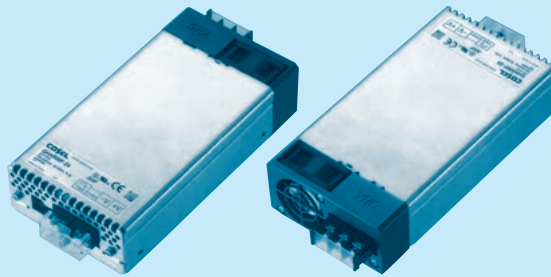

Example recommended EMI/EMC filter
EAC-10-472



High voltage pulse noise type : EAP series
 Low leakage current type : EAM series
 * A higher current rating EMI/EMC filter may be recommended in view of the other devices that could be connected in parallel with the power supply.

- ① Series name
 - ② Single output
 - ③ Output wattage
 - ④ Universal input
 - ⑤ Output voltage
 - ⑥ Optional *6
- J1 : CN501
 PHconnector type(J.S.T.)
 J2 : CN501
 Friction locks connector type (Molex)
 P : Parallel Operation
- Refer to the instruction manual 6.1.

*Make sure necessary tests will be carried out on your end equipment with the power supply installed in accordance with any required EMC/EMI regulations.

MODEL	GHA500F-12-SNF	GHA500F-15-SNF	GHA500F-24-SNF	GHA500F-30-SNF	GHA500F-48-SNF	GHA500F-56-SNF	
MAX OUTPUT WATTAGE[W]	450	501	504	501	504	504	
DC OUTPUT	Forced air +50°C	12V 37.5A	15V 33.4A	24V 21.0A	30V 16.7A	48V 10.5A	56V 9.0A

SPECIFICATIONS

	MODEL	GHA500F-12-SNF	GHA500F-15-SNF	GHA500F-24-SNF	GHA500F-30-SNF	GHA500F-48-SNF	GHA500F-56-SNF					
INPUT	VOLTAGE[V]	AC90 - 264 1 φ (output derating is required at AC90V -115V *3)										
	CURRENT[A]	ACIN 120V	4.8typ	5.4typ								
		ACIN 230V	2.6typ	2.9typ								
	FREQUENCY[Hz]	50 / 60 (47 - 63)										
	EFFICIENCY[%]	ACIN 120V	87typ	89typ	89typ	89typ	89typ	89typ				
		ACIN 230V	89typ	91typ	91typ	91typ	91typ	91typ				
	POWER FACTOR (Io=100%)	ACIN 120V	0.95typ									
		ACIN 230V	0.90typ									
INRUSH CURRENT[A]	ACIN 120V	20typ (Io=100%) (At cold start) (Ta=25°C)										
	ACIN 230V	40typ (Io=100%) (At cold start) (Ta=25°C)										
LEAKAGE CURRENT[mA]	0.125/0.250max (ACIN 120V/240V 60Hz,Io=100%, According to IEC60601-1)											
OUTPUT	VOLTAGE[V]	12	15	24	30	48	56					
	CURRENT[A]	Forced air	37.5	33.4	21.0	16.7	10.5	9.0				
	LINE REGULATION[mV]	*4	48max	60max	96max	120max	192max	192max				
	LOAD REGULATION[mV]	*4	100max	120max	150max	180max	240max	240max				
	RIPPLE[mVp-p]	*1	0 to +50°C	240max	240max	240max	300max	300max	400max			
			-20 - 0°C	320max	320max	320max	400max	400max	500max			
	RIPPLE NOISE[mVp-p]*1		0 to +50°C	300max	300max	300max	480max	480max	500max			
			-20 - 0°C	360max	360max	360max	500max	500max	580max			
	TEMPERATURE REGULATION[mV]		0 to +50°C	120max	150max	240max	300max	480max	480max			
			-20 to +50°C	150max	180max	290max	360max	600max	600max			
	DRIFT[mV]	*2	48max	60max	96max	120max	192max	192max				
	START-UP TIME[ms]	500typ (ACIN 120V, Io=100%)										
	HOLD-UP TIME[ms]	16typ (ACIN 120V, Io=100%)										
OUTPUT VOLTAGE ADJUSTMENT RANGE[V]	10.80 to 13.20		13.50 to 16.50		21.60 to 26.40		27.00 to 31.50		43.20 to 52.80		52.00 to 56.00	
OUTPUT VOLTAGE SETTING[V]	12.00 to 12.48		15.00 to 15.30		24.00 to 24.96		30.00 to 31.20		48.00 to 49.92		55.00 to 56.00	
PROTECTION CIRCUIT AND OTHERS	OVERCURRENT PROTECTION	Works over 105% of rating and recovers automatically *7										
	OVERVOLTAGE PROTECTION[V]	13.80 to 16.80	17.25 to 21.00	27.60 to 33.60	34.50 to 42.00	55.20 to 67.20	60.00 to 69.00					
	AUX1	12V 0.5A										
	AUX2	5V 1A										
	REMOTE ON/OFF	Possible, AUX2 is available										
	PowerGood	Open collector										
ISOLATION	INPUT-OUTPUT · RC · AUX	AC4,000V 1minute, Cutoff current = 10mA, DC500V 50MΩ min (At Room Temperature) 2MOPP										
	INPUT-FG	AC2,000V 1minute, Cutoff current = 10mA, DC500V 50MΩ min (At Room Temperature) 1MOPP										
	OUTPUT · RC · AUX-FG	AC500V 1minute, Cutoff current = 25mA, DC500V 50MΩ min (At Room Temperature)										
	OUTPUT-RC · AUX	AC500V 1minute, Cutoff current = 25mA, DC500V 50MΩ min (At Room Temperature)										
ENVIRONMENT	OPERATING TEMP.,HUMID.AND ALTITUDE	-20 to +70°C, 20 - 90%RH (Non condensing), 3,000m (10,000feet) max *3										
	STORAGE TEMP.,HUMID.AND ALTITUDE	-30 to +80°C, 20 - 90%RH (Non condensing), 9,000m (30,000feet) max										
	VIBRATION	10 - 55Hz, 19.6m/s ² (2G), 3minutes period, 60minutes each along X, Y and Z axis										
	IMPACT	196.1m/s ² (20G), 11ms, once each X, Y and Z axis										
SAFETY AND NOISE REGULATIONS	AGENCY APPROVALS	UL60950-1, ANSI/AAMI ES60601-1, C-UL(CSA60950-1, CAN/CSA60601-1), EN60950-1, EN60601-1 3rd, Complies with DEN-AN, IEC60601-1-2 4th Ed.										
	CONDUCTED NOISE	Complies with FCC-B, VCCI-B, CISPR11-B, CISPR22-B, EN55011-B, EN55022-B										
	HARMONIC ATTENUATOR	Complies with IEC61000-3-2 (class A) *5										
OTHERS	CASE SIZE/WEIGHT	85.2 X 41 X 165.3mm [3.35 X 1.61 X 6.5 inches] (W X H X D) / 660g max										
	COOLING METHOD	Forced air										

*1 This is the value that measured on measuring board with capacitor of 22 μF at 150mm from output terminal.
 Measured by 20MHz oscilloscope or Ripple-Noise meter (Equivalent to KEISOKU-GIKEN: RM103).
 *2 Drift is the change in DC output for an eight hour period after a half-hour warm-up at 25°C, with the input voltage held constant at the rated input/output.
 *3 Refer to "Derating".
 *4 Please contact us about dynamic load and input response.

*5 Please contact us about another class.
 *6 Specification is changed at option, refer to Instruction Manual.
 *7 When output current more than rated, output will shut down after 5 seconds or more. Recycle input after 3 minutes to reset the protection.
 * To meet the specifications. Do not operate over-loaded condition.
 * Sound noise may be generated by power supply in case of pulse load.
 * Parallel operation is available with -P option. Refer to 5.1on the instruction manual.

Features

- Full packaged design united with GHA's features, and additional robustness..
- High efficiency 91% typ (Input voltage 230V,Output voltage 24V)
- 50% minimized size compares with previous products.
- Optical for 1U applications
- Medical and Industrial safety approvals
- Low leakage current
- Conformal coating
- Single remote ON/OFF control for DC output, AUX1 and Fan.
- Isolated dual AUX (AUX1 12V 0.5A, AUX2 5V 1A)

Block diagram

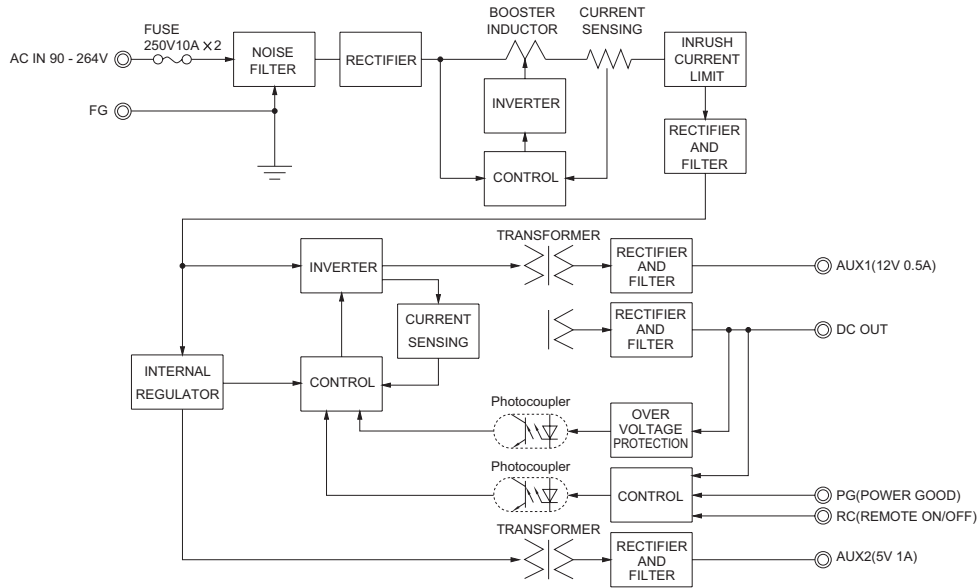

External view

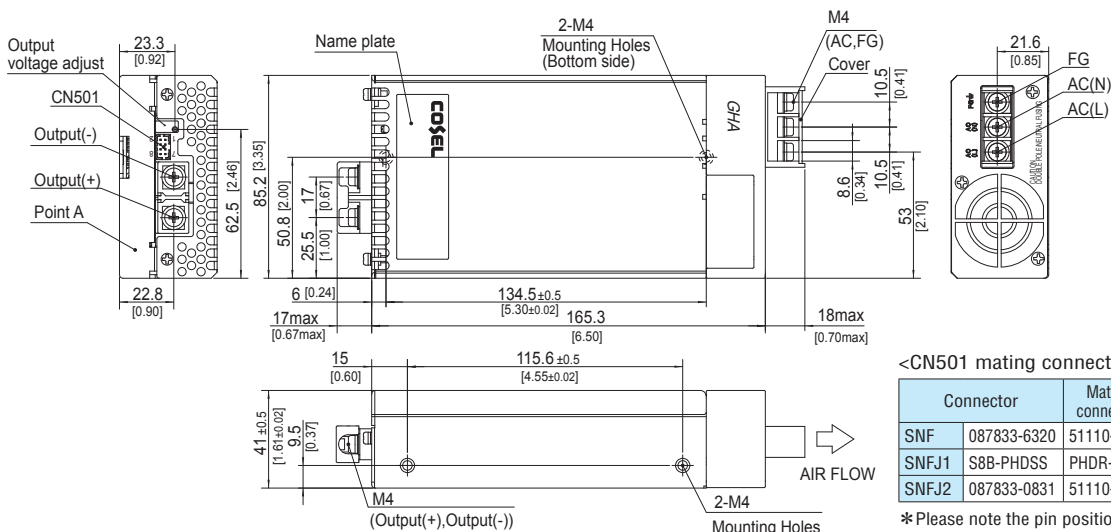

<CN501 mating connector and terminal>

Connector	Mating connector	Terminal	Mfr	
SNF	087833-6320	51110-0851	50394-8051	Molex *
SNFJ1	S8B-PHDSS	PHDR-08VS	SPHD-002T-P0.5	J.S.T.
SNFJ2	087833-0831	51110-0860	50394-8051	Molex *

* Please note the pin position No.1 is different from Molex.

<CN501>

Pin No.	Function
1	AUX1 : AUX1 (12V0.5A)
2	AUX1G: AUX1 (GND)
3	RC : REMOTE ON/OFF
4	RCG : REMOTE ON/OFF (GND)
5	PG : Power good
6	PGG : Power good (GND)
7	AUX2 : AUX2 (5V1A)
8	AUX2G: AUX2 (GND)

- ※ Tolerance ± 1 [±0.04]
- ※ Weight : 660g max
- ※ Upper PCB Material/thickness : FR-4/1.6mm
- ※ Lower PCB Material/thickness : AL/1.5mm
- ※ Chassis Material/thickness : Aluminum/1.5mm
- ※ Cover Material/thickness : Aluminum/1.2mm
- ※ Fan cover Material : PBT
- ※ Mounting torque : 1.5N · m (14.7kgf · cm) max
- ※ Screw tightening torque M4 : 1.6N · m (16.9kgf · cm) max
- ※ Dimensions in mm, []=inches



Assembling and Installation Method

GHA300/500F

Mounting method

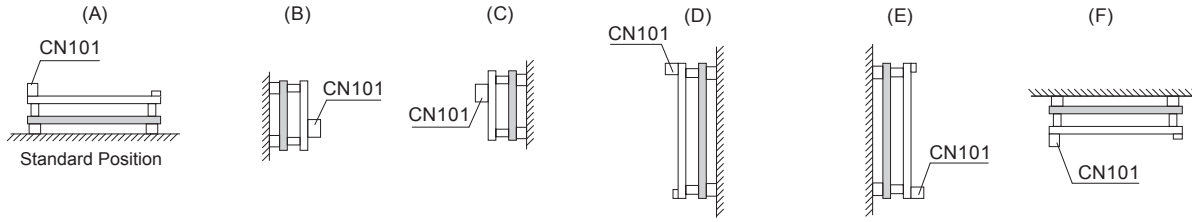

AC voltage exist on the primary side therefore. In order to prevent electric shock, or to meet the leakage current requirements of the safety standard, you need to ensure the proper insulation distance.

During use, keep the distance between $d1$ & $d2$ for to insulate between lead of component and metal chassis, use the spacer of 5mm or more between $d2$. If it is less than $d1$ & $d2$, insert the insulation sheet between power supply and metal chassis.

GHA300F

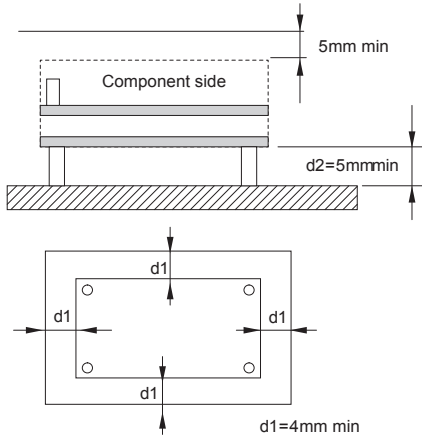

GHA500F

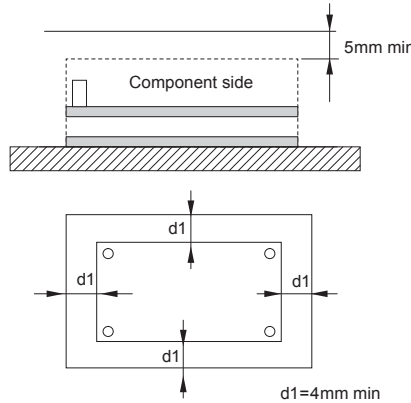

Remarks:

There is a possibility that it is not possible to cool enough when the power supply is used by the sealing up space as showing in right figure.

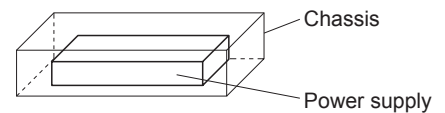

GHA300/500F-SNF

Mounting screw

Screw length into power supply should be shorter than 6mm due to keep safety isolation clearance from inside components in right figure. Please fix power supply surely by screws in consideration of the weight.

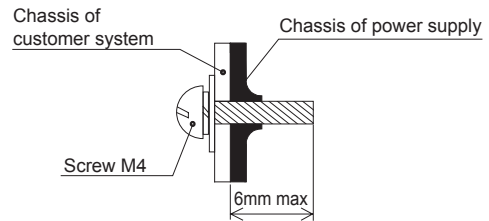

A cooling FAN is built-in. Please keep 30mm or more clearance both input and output side to make enough air ventilation. Do not block off cooling FAN's air flow for stable operation.

When power supply is used where dust exist, it may cause of FAN failure. It is recommended to install a air filter to the system air ventilation duct.

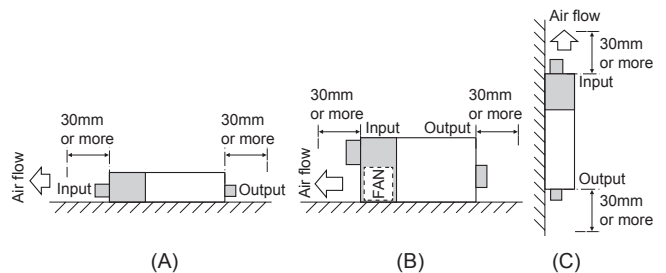

Mounting screw

● **GHA300/500F**

- The mounting screw should be M3. The hatched area shows the allowance of metal parts for mounting.
- If metallic fittings are used on the component side of the board, ensure there is no contact with surface mounted components.
- This product uses SMD technology.
Please avoid the PCB installation method which includes the twisting stress or the bending stress.

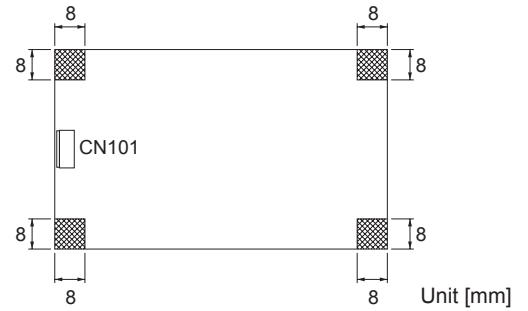

Derating

■ **Cooling method**

Conduction cooling, forced air and convection cooling are available for GHA500F. Both Forced air and convection cooling are available for GHA300F. Please see instruction manual 3 for details. Please make sure the maximum component temperature rise given in instruction manual 3 is not exceeded (Refer to instruction manual 6 for -SNF).

● **Derating curve for input voltage**

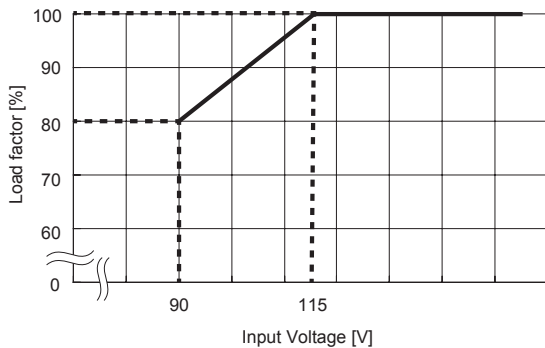

* For maximum power in each cooling method, please apply.

● **GHA500F Ambient temperature derating curve at forced air (Reference value)**

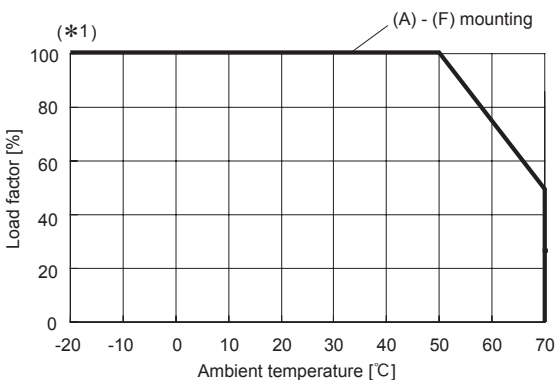

* For the derating curves of other heat dissipation methods, see instruction manual 3.

* 1 The maximum output power by wind speed conditions (Reference value)

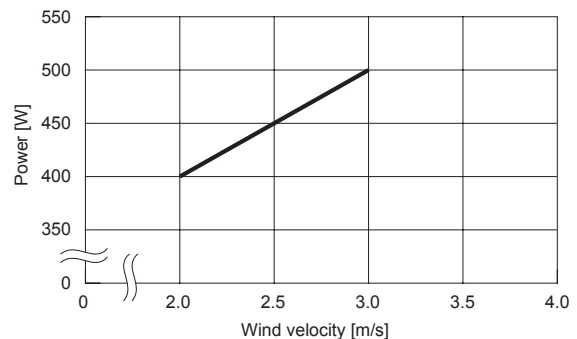

Derating

● GHA300F Ambient temperature derating curve at forced air (Reference value)

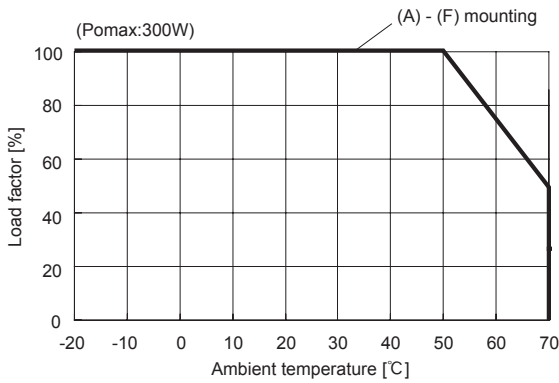

● GHA300/500F-SNF Ambient temperature derating curve (Reference value)

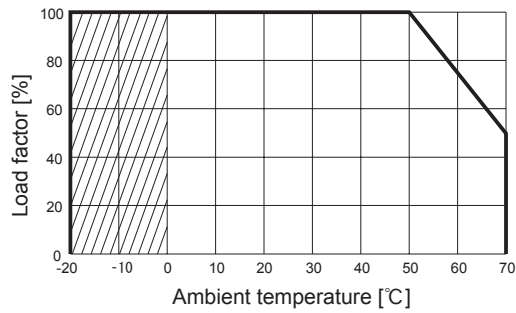

*For the derating curves of other heat dissipation methods, see instruction manual 3.

Instruction Manual

◆ It is necessary to read the "Instruction Manual" and "Before using our product" before you use our product.

Instruction Manual <https://en.cosel.co.jp/product/powersupply/GHA/>
 Before using our product <https://en.cosel.co.jp/technical/caution/index.html>

GHA



NOTICE



Basic Characteristics Data

Model	Circuit method	Switching frequency [kHz]	Input current *1 [A]	Inrush current protection	PCB/Pattern			Series/Parallel operation availability	
					Material	Single sided	Double sided	Series operation	Parallel operation
GHA300F	boost chopper	60 - 220	3.3	Thermistor	FR-4		Yes	Yes	No
	LLC resonant converters	90 - 180							
GHA500F	boost chopper	60 - 220	5.4	Thermistor	Aluminum/FR-4	Yes	Yes	Yes	*2
	LLC resonant converters	90 - 180							
GHA300F-SNF	boost chopper	60 - 220	3.3	Thermistor	FR-4	Yes	Yes	Yes	No
	LLC resonant converters	90 - 180							
GHA500F-SNF	boost chopper	60 - 220	5.4	Thermistor	Aluminum/FR-4	Yes	Yes	Yes	*2
	LLC resonant converters	90 - 180							

*1 The value of input current is at ACIN 120V and rated load.

*2 Parallel operation is available with -P option. Refer to 6.1 on the instruction manual.

Mouser Electronics

Authorized Distributor

Click to View Pricing, Inventory, Delivery & Lifecycle Information:

Cosel:

[GHA500F-48-SNF](#) [GHA500F-12-SNF](#) [GHA500F-24-SNF](#) [GHA500F-15-SNF](#) [GHA500F-12-T3](#) [GHA500F-24-R3](#)
[GHA300F-12-J1](#) [GHA500F-15-T3](#) [GHA300F-12-SNF](#) [GHA500F-15-J1](#) [GHA500F-48-J1](#) [GHA300F-24-SNF](#)
[GHA300F-48-SNF](#) [GHA300F-24-J1](#) [GHA300F-48-J1](#) [GHA300F-12-T3](#) [GHA300F-48-T3](#) [GHA500F-12-J1](#) [GHA500F-48-R3](#) [GHA300F-24-T3](#) [GHA500F-12-R3](#) [GHA500F-24-J1](#) [GHA500F-24-T3](#)